

NOTE:
 WITHOUT INSTALLATION OF STIFFENERS OR BEING AT A PANEL POINT, THIS CONNECTION IS ONLY LOADING ONE ANGLE OF THE DOUBLE ANGLE TOP CHORD OF A JOIST. E.O.R. **MUST** REVIEW AND ACCEPT THAT THE LOAD TO THE JOIST IS ONLY SUPPORTED BY ONE LEG OF JOIST.

SEE SHOP DRAWING FOR FINAL LOCATION OF CROSS RAILS AND SITE SPECIFIC INFORMATION NOT PROVIDED ON THIS SHEET

ISOMETRIC VIEW - QUICKFRAMES ADJUSTABLE FRAME

Main/Cross Rail Limitations:

- A) Cross Rail end reaction shall not exceed 1000 lbs (1.0 Kip) for a single angle connection. Installation contractor to verify loading distribution diagram of supported equipment and place equipment so the allowable loads are not exceeded.
- B) Main Rail end reaction shall not exceed 1160 lbs (1.160 Kip). Installation contractor to verify the loading distribution diagram of supported equipment and place equipment so the allowable loads are not exceeded.
- C) Main Rail shall be installed snug to supporting roof framing.
- D) For Frame Span and Cross Rail opening dimensions with corresponding minimum overlaps, See Dimension Table.
- E) Main Rail designs are based on 2 cross rails loading the main rail at 24" apart minimum with the cross rails centered on main rail. Cross Rail designs are based on a distributed loading from the decking loading the cross rails. Any other variations or loading of these rails is outside the scope of this standard design and it must be evaluated for a site specific application by Caruso Turley Scott.

QuickFrame Material Specifications:

- 1. All Main/Cross Rails shall be a minimum 12 GAGE cold formed material and shall conform to ASTM A653 CS TYPE B Grade 50 KSI.
- 2. All Angle Connections shall be a minimum 12 GAGE cold formed material and shall conform to ASTM A653 CS TYPE B Grade 50 KSI.
- 3. All End Connections shall be a minimum 3/16" material and shall conform to ASTM A36 Steel.
- 4. All bolts shall be 1/2" diameter x 1" long SAE Grade 5 or SAE Grade 8.2 carriage bolts with nuts.
 - 4a. Angle connections shall contain 2 bolts in each leg.
 - 4b. End connections shall contain 2 bolts in main rail.
 - 4c. Main/Cross Rail splice connection shall contain 1 bolt (minimum) at each end of splice. The bolts for angle connectors may not be used as splice bolts.

Design Criteria:

Building / Design Codes:	2021/2018/2015/2012/2009/2006/2003 International Building Code (IBC) ASCE / SEI 7-05/7-10/7-16 AISI 2007/2010/2012/2016 North American Specification (NAS)
Wind Load (Maximum):	90 MPH, Exposure C (2003 to 2009 IBC) 115 MPH, Exposure C (2012 to 2021 IBC) Building Mean Roof Height = 25'-0"
Seismic Load (Maximum):	Seismic Design Category B S _{ps} < 0.33; S _{d1} < 0.133
Snow Load (Maximum):	20 PSF Flat Roof Load (See Note 3)
Dead / Live Load (Maximum):	20 PSF / 20 PSF (See Note 5)

- Notes:**
- 1) Maximum Frame Loads shown in the table are based on the above maximum design loads. Contact QuickFrames if above loads are exceeded because site specific layouts can be designed.
 - 2) Maximum Loads shown for all spans and material strengths do not exceed a L/240 deflection ratio.
 - 3) Snow Drift loads are not included in design. All sides of the roof projections supported by the frame shall be less than 15 feet long per ASCE 7-05 and 7-10 Section 7.8.
 - 4) Dead/Live Loads are roof structure dead and live loads bearing on frame.
 - 5) Building Dead Loads between the cross rails are not included in the design as roof opening sizes vary by application. Any dead load remaining between the cross rails must be deducted from the loads shown in this table for allowable loading. Site-specific engineering is also available upon request. Edges of any cut roof diaphragm material should always be mechanically attached to roof support member. Mechanical attachment should be per building structural engineer of record. At a minimum, attachment per detail 02 should be installed.
 - 6) QuickFrames installation shall conform to the QuickFrames installation instructions.

Note:
 MAXIMUM LOADS SHOWN ARE FOR THE QUICKFRAMES ADJUSTABLE FRAME ONLY. BUILDING ROOF STRUCTURE FRAMING CAPACITY (EXISTING OR NEW) SHALL BE CHECKED BY A REGISTERED STRUCTURAL ENGINEER TO ENSURE THE PROPOSED LOAD ON THE FRAME DOES NOT OVERSTRESS ANY ROOF SUPPORTING FRAME MEMBERS AND/OR BUILDING COMPONENTS.



Project Information:

• Roof Structure Type:	XXX
• Roof Material:	XXX
• QuickFrame Span:	XXX
• Equipment Type:	XXX
• Equipment Weight:	XXX
• Equipment Height:	4'-0" MAX

SEAL:
 THIS SHEET IS INTENDED FOR PRELIMINARY USE ONLY AND IS NOT FOR PERMIT OR CONSTRUCTION UNLESS ADDRESS OF SITE IS SHOWN IN TITLE BLOCK AND THE STRUCTURAL ENGINEER OF RECORD'S SEAL IS AFFIXED WITH WRITTEN SIGNATURE.

STANDARD SHEET REVISION DATE: 12/02/24
 THIS SHEET IS INTENDED FOR GENERAL USE ONLY AND IS NOT CONSIDERED SITE SPECIFIC UNLESS ADDRESS OF SITE IS SHOWN IN TITLE BLOCK AND THE STRUCTURAL ENGINEER OF RECORDS SEAL IS AFFIXED WITH WRITTEN SIGNATURE.

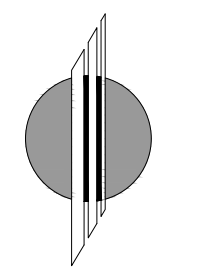

**CARUSO
 TURLEY
 SCOTT**
 structural engineers

1215 W. Rio Salado Pkwy
 Suite 200
 Tempe, Arizona 85281
 (480) 774-1700
 www.ctsaz.com

XXX
 XXX
 XXX



710 W. Broadway Rd. Suite 503 Mesa, Arizona 85210
 Office: 480.464.1500 Sales: 480.656.1575
 Website: www.quickframes.com
 Email: sales@quickframes.com



JOB NUMBER: 24-0120-XXX		
DRAWN: TMH	ENGINEER: XXX	CHECKED: DEE
RAIL: 12 GAUGE	SCALE: N.T.S.	
DATE: XX/XX/2024		
SHEET: S12A		

12 gauge X 50 KSI 6"x2" Rail Design - Light Machinery Design - Two Cross Rails Load the Main Rail with 2 Point Loads - One 12 ga x 50 ksi Angle Connector at Each Cross Rail Connection to Main Rail - 3/16" x 36 ksi End Connector with Vertical Weld - Up to 2021 IBC - No Dead Load Between Cross Rails - Cross Rails Centered on Main Rail

Per IBC Section 1607.8.2 or 1607.9.2, at frames supporting light machinery (shaft or motor driven), the Maximum Frame Loads shown have been reduced by 20%.
Also, an industry standard unbalanced mechanical loading of 2/3 and 1/3 is included.

				Maximum Cross Rail Span												
				20 in	30 in	36 in	39 in	48 in	60 in	66 in	72 in	84 in	96 in	102 in	108 in	120 in
DEAD LOAD = 20 PSF				1.67 ft	2.50 ft	3.00 ft	3.25 ft	4.00 ft	5.00 ft	5.50 ft	6.00 ft	7.00 ft	8.00 ft	8.50 ft	9.00 ft	10.00 ft
LIVE LOAD = 20 PSF				15 in	20 in	25 in	30 in	35 in	40 in	45 in	50 in	55 in	60 in	65 in	70 in	75 in
SNOW LOAD = 20 PSF		Cross Rails		10 in	10 in	14 in	21 in	22 in	20 in	24 in	28 in	26 in	24 in	28 in	32 in	30 in
WIND LOAD = 7.8 PSF		Min Overlap														
Max Main Rail Clear Span	Main Rails	Min Overlap														
24 in	2.00 ft	20 in	16 in	3321 lb	3290 lb	3271 lb	3262 lb	3234 lb	3196 lb	3178 lb	3159 lb	3121 lb	3084 lb	3065 lb	3047 lb	2439 lb
30 in	2.50 ft	25 in	20 in	3308 lb	3270 lb	3248 lb	3236 lb	3202 lb	3157 lb	3135 lb	3112 lb	3067 lb	3022 lb	2999 lb	2976 lb	2127 lb
42 in	3.50 ft	30 in	18 in	2871 lb	2817 lb	2785 lb	2769 lb	2720 lb	2656 lb	2623 lb	2591 lb	2526 lb	2461 lb	2429 lb	2397 lb	1347 lb
36 in	3.00 ft	30 in	24 in	3295 lb	3251 lb	3224 lb	3211 lb	3171 lb	3118 lb	3092 lb	3065 lb	3012 lb	2959 lb	2933 lb	2906 lb	1815 lb
48 in	4.00 ft	35 in	22 in	3000 lb	2940 lb	2903 lb	2885 lb	2831 lb	2758 lb	2722 lb	2686 lb	2613 lb	2541 lb	2504 lb	2225 lb	1035 lb
54 in	4.50 ft	40 in	26 in	3043 lb	2976 lb	2936 lb	2916 lb	2856 lb	2775 lb	2735 lb	2695 lb	2615 lb	2534 lb	2494 lb	1944 lb	Use 10 GA.
60 in	5.00 ft	45 in	30 in	2692 lb	2616 lb	2570 lb	2547 lb	2478 lb	2386 lb	2340 lb	2294 lb	2202 lb	2110 lb	2064 lb	1523 lb	Use 10 GA.
66 in	5.50 ft	50 in	34 in	3230 lb	3153 lb	3107 lb	3084 lb	3015 lb	2923 lb	2877 lb	2831 lb	2739 lb	2647 lb	2288 lb	1523 lb	Use 10 GA.
72 in	6.00 ft	55 in	38 in	3217 lb	3134 lb	3084 lb	3059 lb	2984 lb	2884 lb	2834 lb	2784 lb	2685 lb	2585 lb	2023 lb	1242 lb	Use 10 GA.
78 in	6.50 ft	60 in	42 in	3204 lb	3114 lb	3060 lb	3034 lb	2953 lb	2845 lb	2791 lb	2738 lb	2630 lb	2522 lb	1758 lb	Use 10 GA.	Use 10 GA.
84 in	7.00 ft	65 in	46 in	3191 lb	3095 lb	3037 lb	3008 lb	2922 lb	2806 lb	2748 lb	2691 lb	2575 lb	2405 lb	1493 lb	Use 10 GA.	Use 10 GA.
90 in	7.50 ft	70 in	50 in	3178 lb	3075 lb	3014 lb	2983 lb	2890 lb	2767 lb	2706 lb	2644 lb	2521 lb	2155 lb	1227 lb	Use 10 GA.	Use 10 GA.
96 in	8.00 ft	75 in	54 in	3165 lb	3056 lb	2990 lb	2957 lb	2859 lb	2728 lb	2663 lb	2597 lb	2466 lb	1906 lb	Use 10 GA.	Use 10 GA.	Use 10 GA.
102 in	8.50 ft	80 in	58 in	3102 lb	2986 lb	2917 lb	2882 lb	2778 lb	2639 lb	2570 lb	2500 lb	2361 lb	1656 lb	Use 10 GA.	Use 10 GA.	Use 10 GA.
108 in	9.00 ft	85 in	62 in	2849 lb	2727 lb	2654 lb	2617 lb	2507 lb	2361 lb	2287 lb	2214 lb	2067 lb	1406 lb	Use 10 GA.	Use 10 GA.	Use 10 GA.
120 in	10.00 ft	85 in	50 in	1663 lb	1528 lb	1447 lb	1406 lb	1284 lb	1122 lb	1041 lb	Use 10 GA.	Use 10 GA.	Use 10 GA.	Use 10 GA.	Use 10 GA.	Use 10 GA.

Refer to all notes on accompanying sheets for cross rail and end connection limitations.

Note:
MAXIMUM LOADS SHOWN ARE FOR THE QUICKFRAMES ADJUSTABLE FRAME ONLY. BUILDING ROOF STRUCTURE FRAMING CAPACITY (EXISTING OR NEW) SHALL BE CHECKED BY A REGISTERED STRUCTURAL ENGINEER TO ENSURE THE PROPOSED LOAD ON THE FRAME DOES NOT OVERSTRESS ANY ROOF SUPPORTING FRAMING MEMBERS AND/OR BUILDING COMPONENTS.



Design Criteria:

Building / Design Codes: 2021/2018/2015/2012/2009/2006/2003 International Building Code (IBC)
ASCE / SEI 7-05/7-10/7-16
AISI 2007/2010/2012/2016 North American Specification (NAS)

Wind Load (Maximum): 90 MPH, Exposure C (2003 to 2009 IBC)
115 MPH, Exposure C (2012 to 2021 IBC)
Building Mean Roof Height = 25'-0"

Seismic Load (Maximum): Seismic Design Category B
S_{ps} < 0.33; S_{p1} < 0.133

Snow Load (Maximum): 20 PSF Flat Roof Load (See Note 3)

Dead / Live Load (Maximum): 20 PSF / 20 PSF (See Note 5)

Notes:

- 1) Maximum Frame Loads shown in the table are based on the above maximum design loads. Contact QuickFrames if above loads are exceeded because site specific layouts can be designed.
- 2) Maximum Loads shown for all spans and material strengths do not exceed a L/240 deflection ratio.
- 3) Snow Drift loads are not included in design. All sides of the roof projections supported by the frame shall be less than 15 feet long per ASCE 7-05 and 7-10 Section 7.8.
- 4) Dead/Live Loads are roof structure dead and live loads bearing on frame.
- 5) Building Dead Loads between the cross rails are not included in the design as roof opening sizes vary by application. Any dead load remaining between the cross rails must be deducted from the loads shown in this table for allowable loading. Site-specific engineering is also available upon request.
- 6) QuickFrames installation shall conform to the QuickFrames installation instructions.

Project Information:

- Roof Structure Type: XXX
- Roof Material: XXX
- QuickFrame Span: XXX
- Equipment Type: XXX
- Equipment Weight: XXX
- Equipment Height: 4'-0" MAX

SEAL:
THIS SHEET IS INTENDED FOR PRELIMINARY USE ONLY AND IS NOT FOR PERMIT OR CONSTRUCTION UNLESS ADDRESS OF SITE IS SHOWN IN TITLE BLOCK AND THE STRUCTURAL ENGINEER OF RECORD'S SEAL IS AFFIXED WITH WRITTEN SIGNATURE.

STANDARD SHEET REVISION DATE: 9/23/21

THIS SHEET IS INTENDED FOR GENERAL USE ONLY AND IS NOT CONSIDERED SITE SPECIFIC UNLESS ADDRESS OF SITE IS SHOWN IN TITLE BLOCK AND THE STRUCTURAL ENGINEER OF RECORDS SEAL IS AFFIXED WITH WRITTEN SIGNATURE.

XXX
XXX
XXX

QUICKFRAMES
QUICKFRAMES USA, LLC
710 W. Broadway Rd. Suite 503 Mesa, Arizona 85210
Office: 480.464.1500 Sales: 480.656.1575
Website: www.quickframes.com
Email: sales@quickframes.com

JOB NUMBER: 21-0120-XXX

DRAWN: TMH	ENGINEER: XXX	CHECKED: DEE
RAIL/CONNECTORS: XXXX	SCALE: N.T.S.	
DATE: XX/XX/2021		
SHEET: S12B		

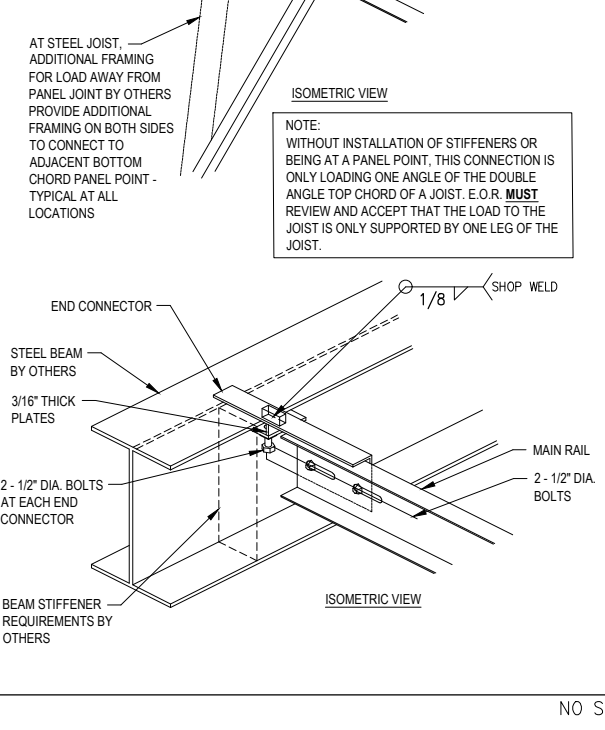
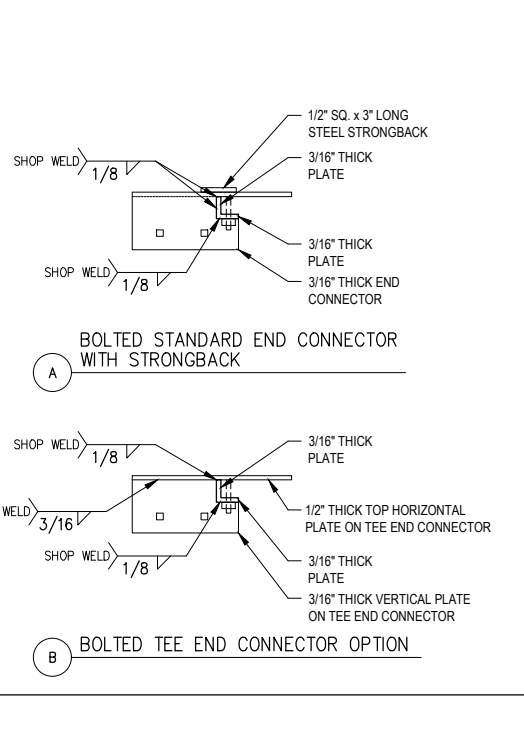
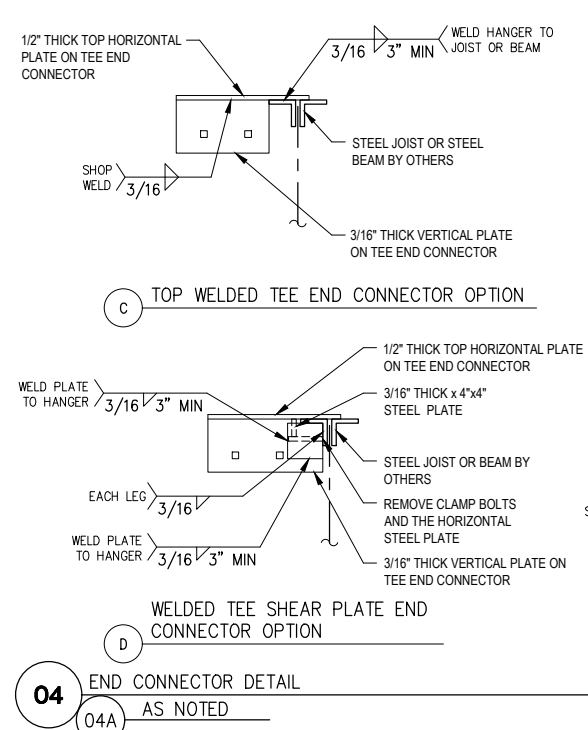
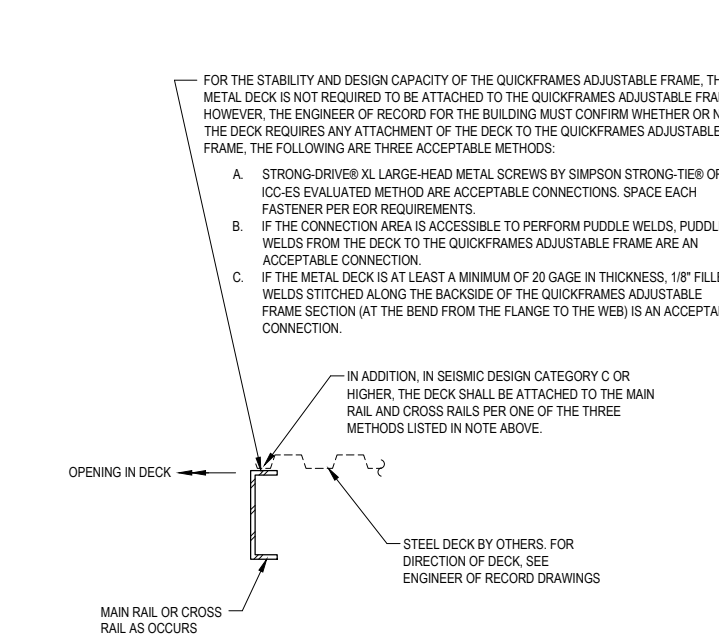
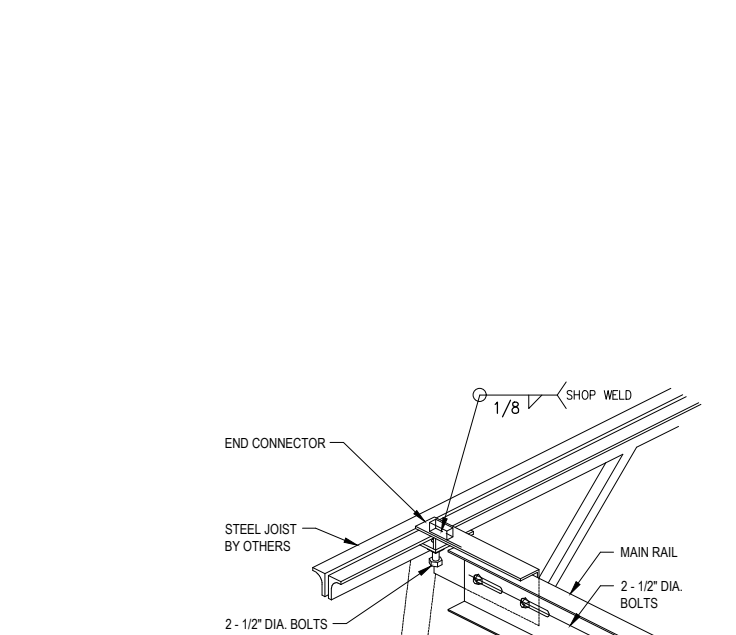
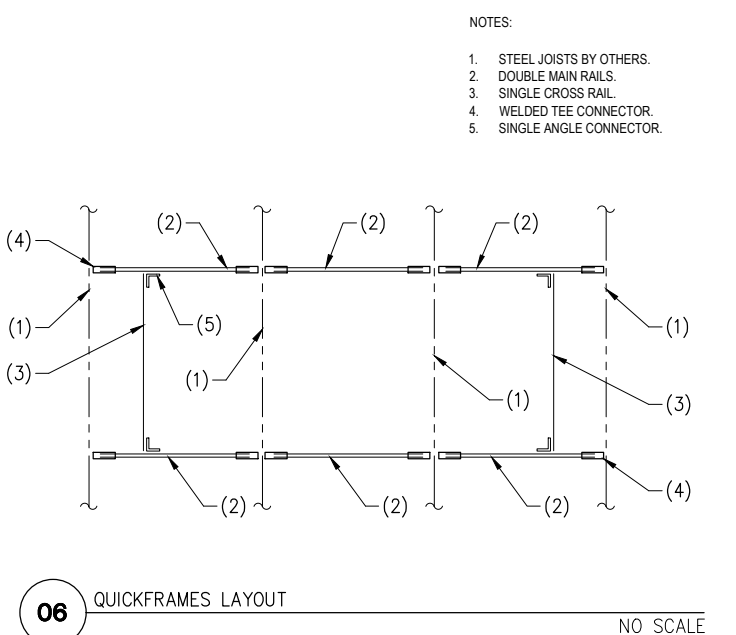
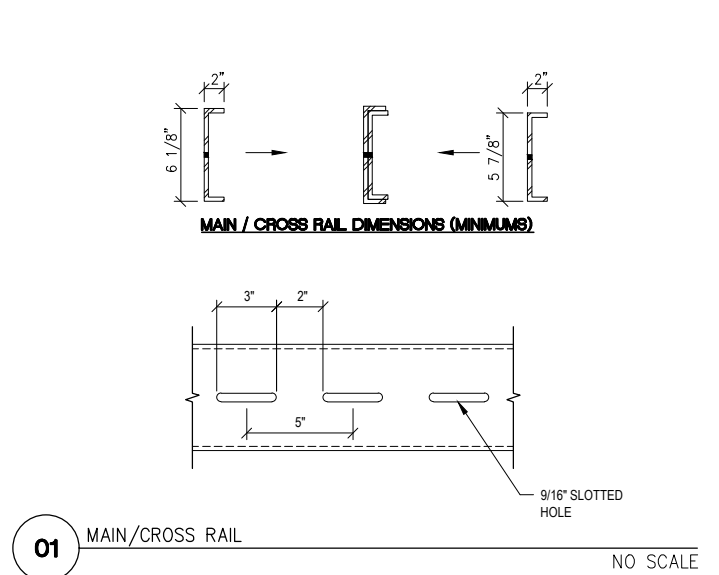
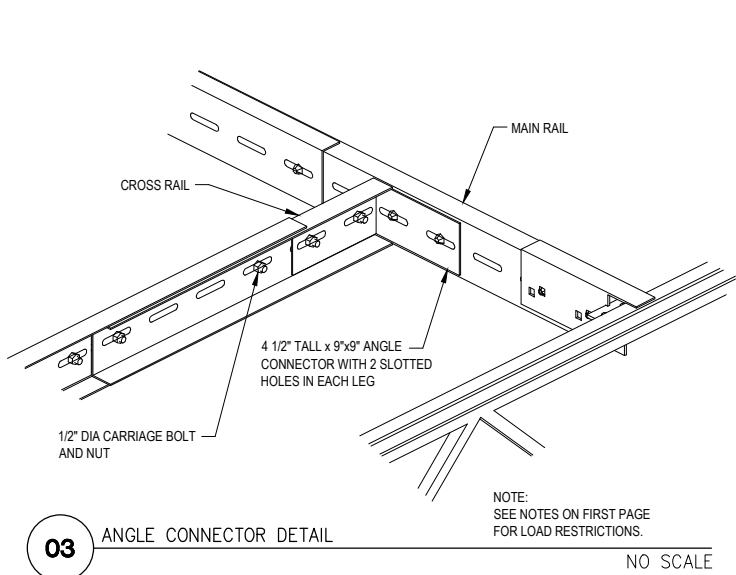
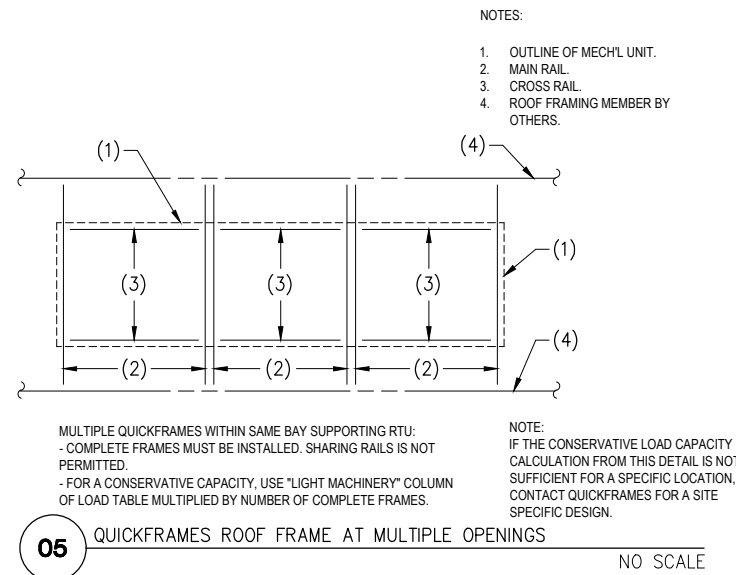

SEAL:

THIS SHEET IS INTENDED FOR PRELIMINARY USE ONLY AND IS NOT FOR PERMIT OR CONSTRUCTION UNLESS ADDRESS OF SITE IS SHOWN IN TITLE BLOCK AND THE STRUCTURAL ENGINEER OF RECORD'S SEAL IS AFFIXED WITH WRITTEN SIGNATURE.

JOB NUMBER: 24-0120-XXX		
DRAWN: TMH	ENGINEER: XXX	CHECKED: DEE
RAIL/CONNECTORS: XXXX		SCALE: N.T.S.
DATE: XX/XX/2024		
SHEET: S1A		

THIS SHEET IS INTENDED FOR GENERAL USE ONLY AND IS NOT CONSIDERED SITE SPECIFIC UNLESS ADDRESS OF SITE IS SHOWN IN TITLE BLOCK AND THE STRUCTURAL ENGINEER OF RECORDS SEAL IS AFFIXED WITH WRITTEN SIGNATURE.

QUICKFRAMES USA, LLC
710 W. Broadway Rd. Suite 503 Mesa, Arizona 85210
Office: 480.464.1500 Sales: 480.656.1575
Website: www.quickframes.com
Email: sales@quickframes.com

XXX
XXX
XXX

STANDARD SHEET REVISION DATE: 11/18/24